

536626

Automated High-Bay Warehouse 9V

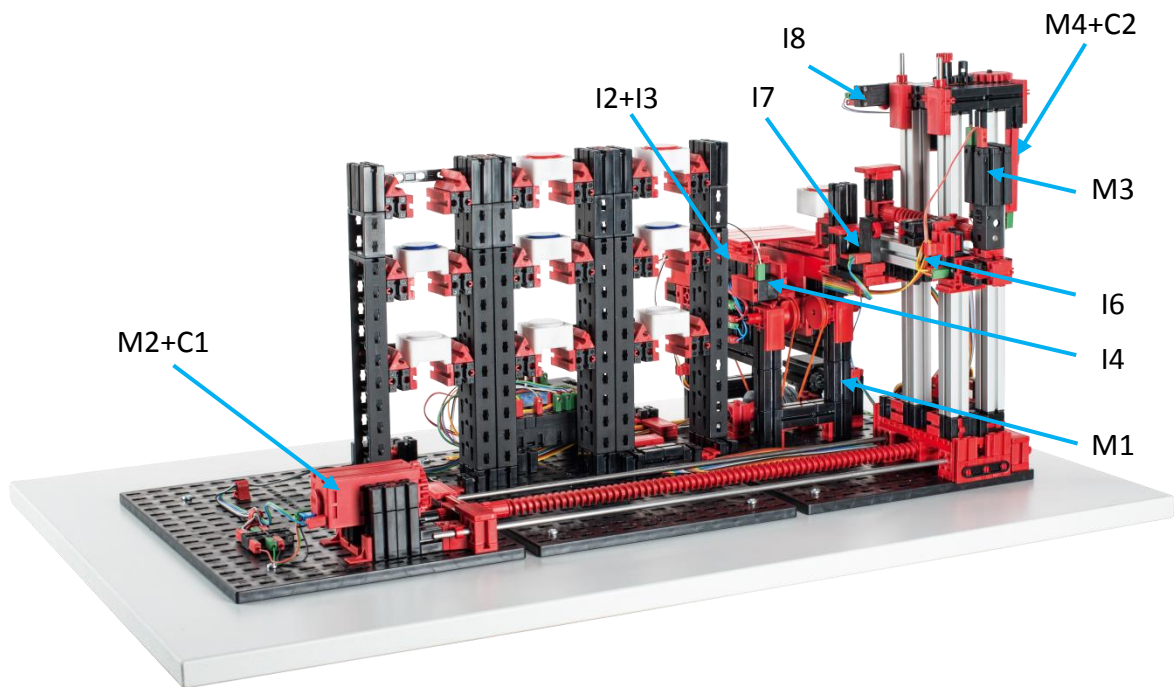

Circuit layout of the Automated High-Bay Warehouse

Number	Function	Input/Output
1	phototransistor outside	I1
2	trail sensor (signal 1)	I2
3	trail sensor (signal 2)	I3
4	phototransistor inside	I4
5	reference switch horizontal axis	I5
6	reference switch cantilever back	I6
7	reference switch cantilever front	I7
8	reference switch vertical axis	I8
9	encoder horizontal axis	C1
10	encoder vertical axis	C2
11	motor conveyer belt	M1
12	motor horizontal	M2
13	motor cantilever	M3
14	motor vertical axis	M4

Technical data

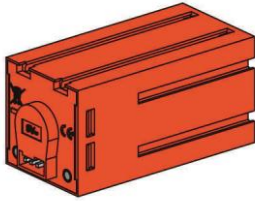

Encoder motor:

The automated high-bay warehouse is powered by three encoder motors. This is possible through permanent magnet DC motors, which enable the incremental measurement of angles with the help of Hall effect sensors. The encoder motors operate at a rated voltage of 9V DC and have a maximum output of 1.2 W at 105 rpm. The current input at maximum power is 386 mA. The integrated gearbox gear ratio is 21.1:1. This means that the encoder produces three pulses per motor shaft rotation or 63.3 pulses per rotation of the gearbox output shaft. Since only one pulse is indexed, the encoder used cannot distinguish the direction in which the motor is rotating.

The encoder is connected to the TXT controller via a triple core cable with a red wire for the 9 V output and a green wire for the ground connection. The black cable transmits the signal (NPN open collector output, 1 kHz max.) and needs to be connected to a fast counter input (C1-C4). If a fischertechnik controller will not be used to read out the encoder signal, the use of a pull-up resistor (4.7-10k Ω) is required.

Phototransistor:



Phototransistors are used as light barriers for the automated high-bay warehouse. In the process, the phototransistor conducts electricity from a certain level of brightness. However, if this luminescence threshold is exceeded, the phototransistor loses its conductivity. Together with a lens tip lamp, which faces the phototransistor, the phototransistor usually conducts electricity and can thus be used as a light barrier. A stray light hood can be used to reduce the effects of ambient light.

Caution: When connecting the phototransistor to the power supply, pay particular attention to correct polarity. Connect the positive pole at the red marking on the phototransistor.

Mini-switch:

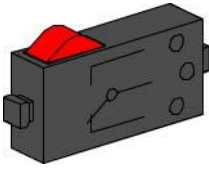

Mini-switches are used as reference switches for the automated high-bay warehouse. When using incremental measuring methods, a reference switch is used to determine the absolute position or absolute angle. The mini-switch used for this purpose includes a changeover switch and can be used both as a normally closed contact and as a normally open contact. When the switch is actuated, equipotential bonding occurs between contact 1 and contact 3, while the connection between contact 1 and contact 2 is separated. Figure 1 shows the schematic circuit diagram of the mini-switch.

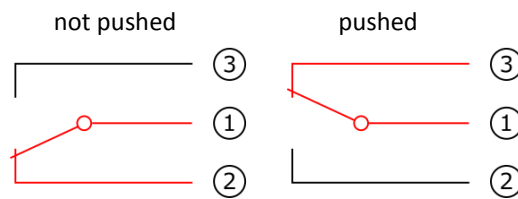
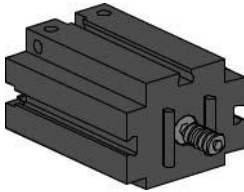

Fig. 1: Mini-switch circuit diagram

S motor:



The high-bay rack feeder boom is powered by an S motor. This compact motor is a permanent magnet DC motor that can be used together with an attachable motor reducing gearbox. The motor is operated at a rated voltage of 9V DC and the maximum current input is 650 mA. The result is a maximum torque of 4.8 mNm and an idling speed of 9,500 rpm. The motor reducing gearbox has a gear ratio of 64.8:1 and a lateral output.

IR trail sensor:

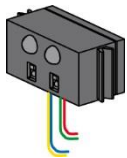

The IR trail sensor is a digital infrared sensor for the identification of a black trail on a white background at a distance of five to 30 mm. It consists of two transmission and two receiver elements. Two universal inputs and the 9V voltage output are required for the connection.

What is a high-bay warehouse?

A high-bay warehouse is a space-saving storage area for storing and retrieving goods. In most cases high-bay warehouses are designed as pallet rack storage systems. This standardization provides for a high level of automation and connection to an ERP (Enterprise Resource Planning) system. High-bay warehouses are characterized by superior space utilization and high initial capital costs.

Storing and retrieving goods is handled by rack feeders that move in a lane between two rows of racks. This area is part of the receiving station, where identification of goods also takes place. Using conveyor systems, such as chain, roller or vertical conveyors, the goods arrive and are transferred to the rack feeders. If the rack feeders are automated, no one is allowed to enter this area. In the case of the automated high-bay warehouse, the goods are provided on a conveyor belt. The goods are identified by a barcode, which is ready by the trail sensor.

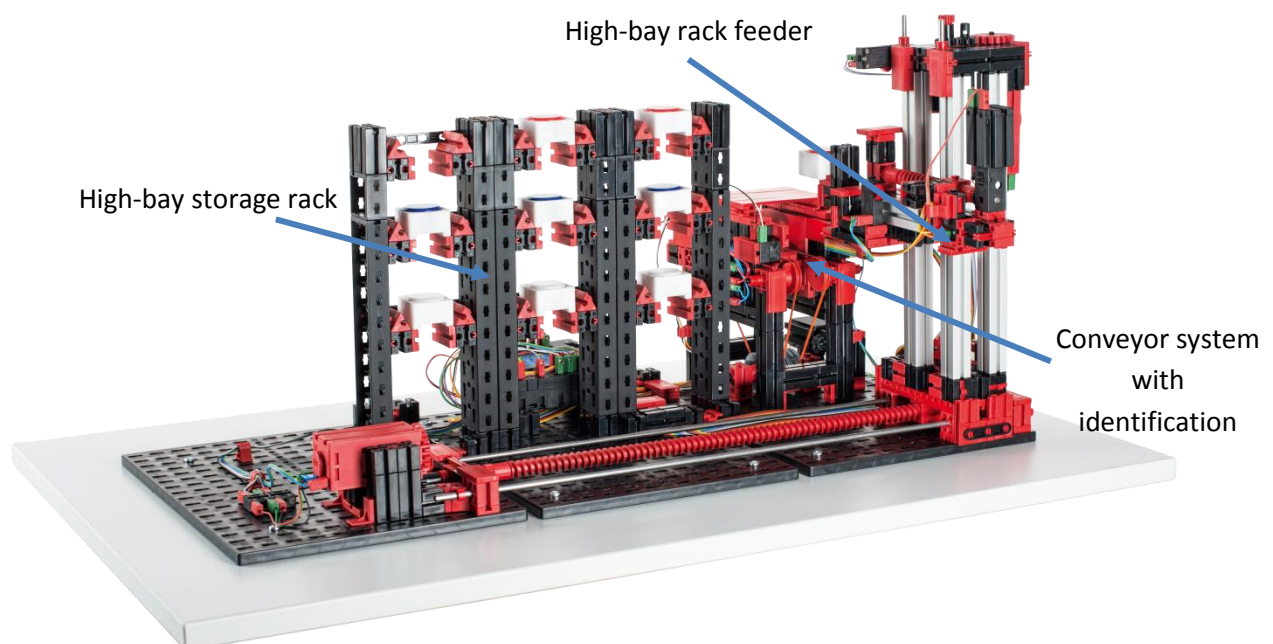

Fig. 1: High-bay warehouse areas

Goods are frequently stored based on the dynamic warehousing principle. There is no fixed arrangement between storage position and goods, so the goods to be stored are placed in any free spot. This promises path efficiency. The warehouse management system saves the position of the stored goods, making them available. A (partly) automated identification of goods, which is usually done using FRID chips or barcodes at a central location called the identification site, and standardization of storage areas (same external dimensions, same permitted unit weights) are indispensable. The ABC strategy in which the warehouse is divided into three zones at varying distances from the storage/retrieval area, is used to further streamline the pathways. Frequently required goods are placed in the A zone, which is directly next to the storage/retrieval area. Rarely needed goods are correspondingly stored in the C zone, which is far away from the storage/retrieval area.

In the case of the automated high-bay warehouse, it is possible to visually demonstrate static and dynamic warehousing. In the case of static warehousing, for instance, each row is assigned a color.

For instance, the top row is assigned the color white, the middle row is assigned red and the bottom row is assigned blue. The individual colored rows are filled from the position closest to the pre-loading zone to the position farthest away from the pre-loading zone. In the case of dynamic storage, there is no fixed assignment between rack row and color. This results in the high-bay rack feeder storing the workpiece in any spot available. The assignment between color and selected storage position has to be saved by the warehouse management system.

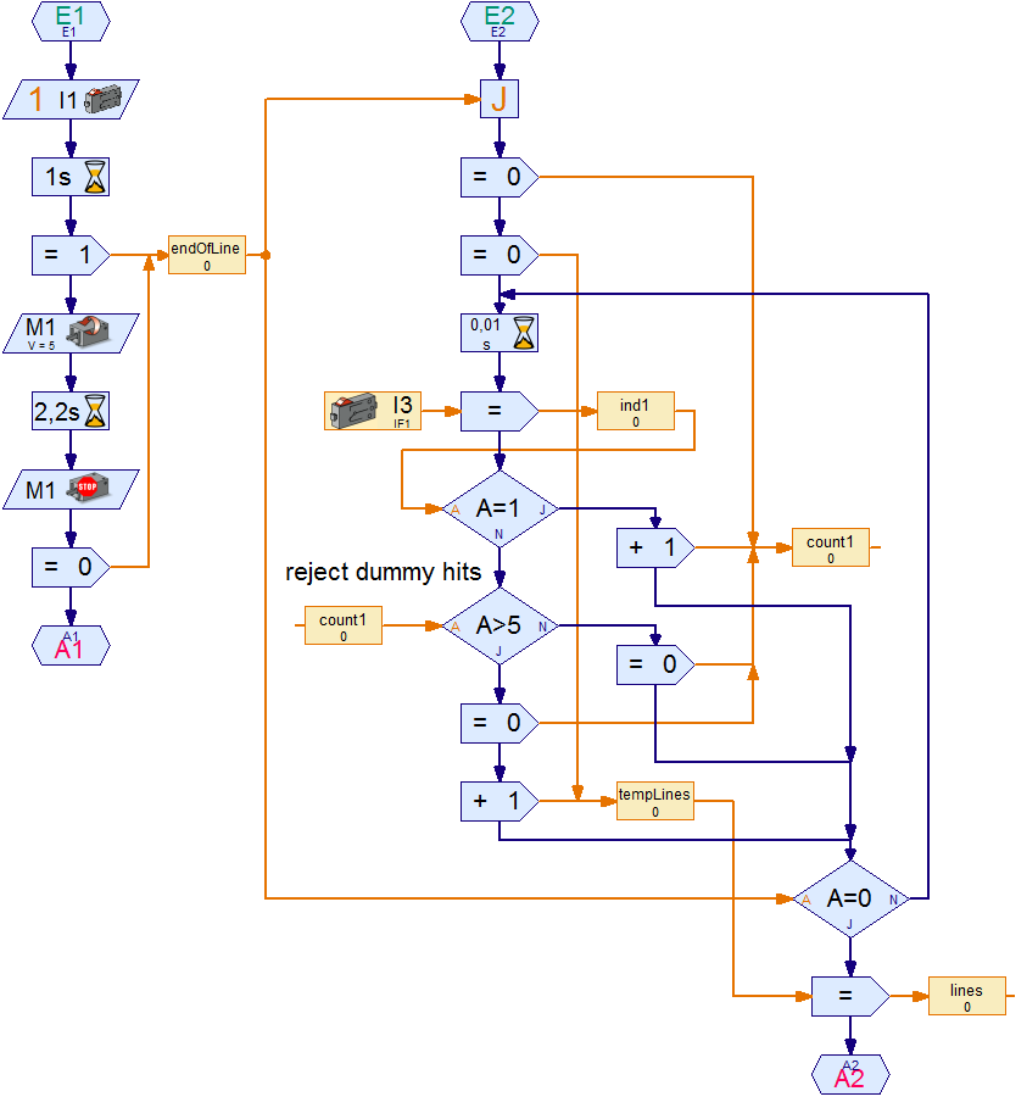

Fig. 2: Algorithm for barcode recognition in ROBOPro

The workpiece is identified by the automated high-bay warehouse using a simple barcode. The workpiece carriers have a code on them, which is assigned the color white, red or blue. This code is analyzed by a trail sensor. The trail sensor registers the differences in light and dark and interprets these either as a mark or as a reflection depending on the width. Reflections occur frequently on the edges of workpiece carriers and need to be dismissed in order to prevent false interpretations. The difference is detected as a result of the width of the dark areas or the number of sequential time increments that are interpreted as dark. The dark areas with more than five sequential time increments are considered a mark. Figure 2 shows how this algorithm is implemented for barcode

detection in ROBOPro. This thus defined minimum width limits the number of patterns to be distinguished which can be used to identify the workpiece, but it is sufficient for coding the three colors.

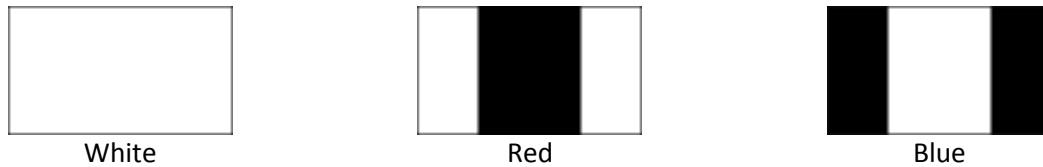

Fig. 3: Color codes

Figure 3 shows the assignment between the codes used and the respective colors. These marks are applied to the workpiece carrier side facing the trail sensor, thus allowing assignment of a workpiece carrier to a colored workpiece.

Calibration

The positions traveled by the automated high-bay warehouse feeder are stored in the “Calibration” subroutine. The positions describe the location of the high-bay storage rack slots and the location of the conveyor belt relative to the zero position of the feeder. Only the X and Y positions that are reached using the encoder motors are taken into account. The Z positions that are reached with an S motor are reached with the help of push-button switches and therefore do not need to be calibrated. The ten positions (new storage locations + conveyor belt) are described with the help of eight variables. For the storage locations, the levels (three X positions) and rack rows (three Y positions) are stored as variables. In the case of the conveyor belt, the X and Y positions are also stored.

Table 1: Predefined and modified positions of the high-bay warehouse

Position	Variable name	Predefined value	Adjusted value
Conveyor belt (X position)	X_0	10	
Conveyor belt (Y position)	Y_0	729	
First row	X_1	760	
Second row	X_2	1365	
Third row	X_3	1972	
Top level	Y_1	85	
Middle level	Y_2	460	
Bottom level	Y_3	850	

High-bay warehouse – definition and characteristics

What is a high-bay warehouse?

What is the pre-loading zone?

Identify and label the important areas of the automated high-bay warehouse.

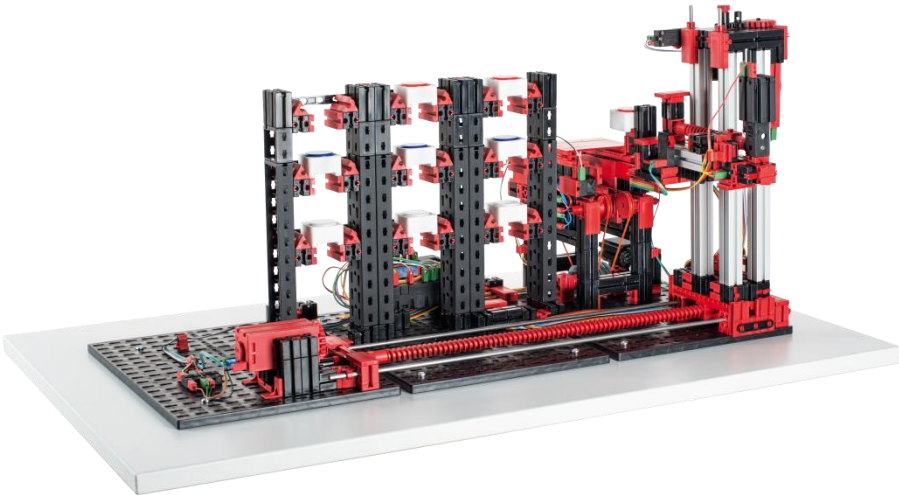

High-bay warehouse – definition and characteristics

ANSWER

What is a high-bay warehouse?

A high-bay warehouse is a space-saving storage area for computer-assisted storage and retrieval of goods and as a result of high standardization provides for a high level of automation.

What is the pre-loading zone?

The pre-loading zone is the high-bay warehouse area where the goods are prepared and identified. The pre-loading zone also includes the high-bay rack feeder and conveyor system.

Identify and label the important areas of the automated high-bay warehouse.

1 High-bay storage rack

2 Conveyor system with identification

3 High-bay rack feeder

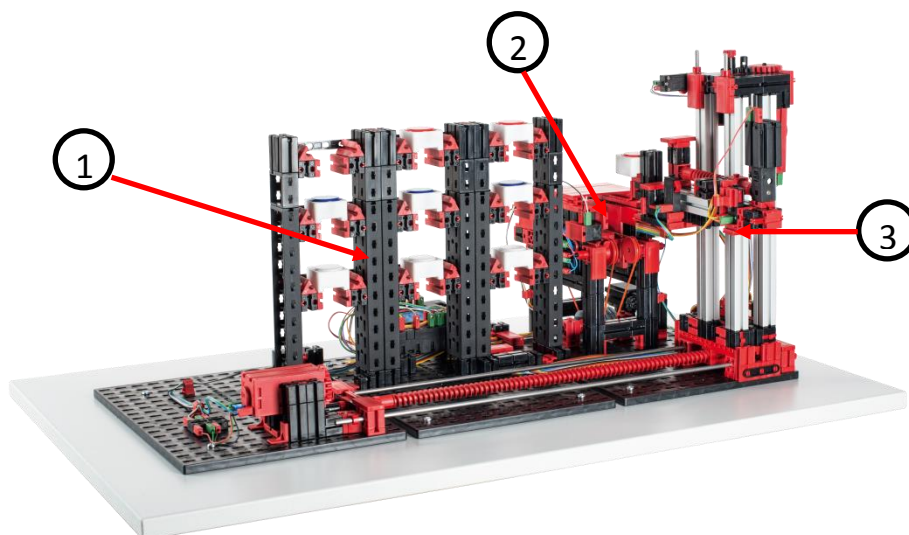

Dynamic warehousing

What are the two requirements for using dynamic warehousing?

What does dynamic warehousing promise?

How can dynamic warehousing be streamlined further?

Use the ABC strategy on the automated high-bay warehouse.

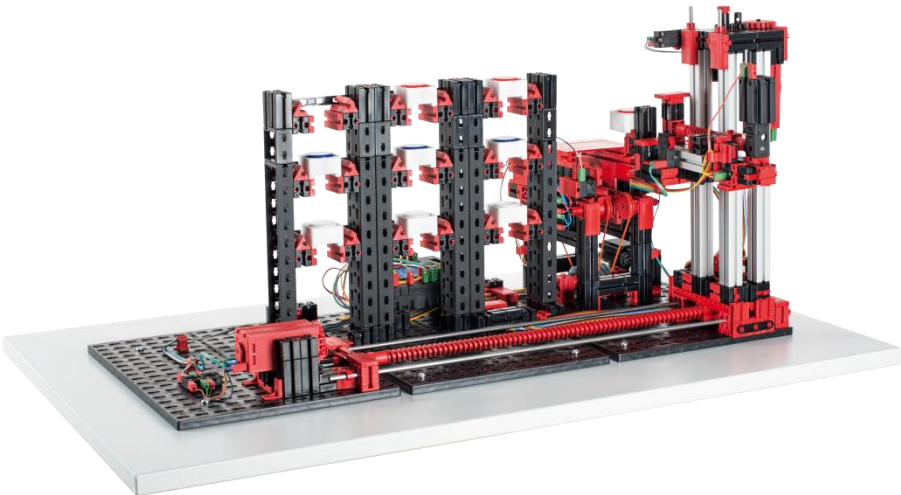

Dynamic warehousing

ANSWER

What are the two requirements for using dynamic warehousing?

- *(Partially) automated identification of goods*
- *Standardization of storage areas*

What does dynamic warehousing promise?

- *Streamlined pathways*
- *Efficient utilization of storage space*

How can dynamic warehousing be streamlined further?

By using the ABC strategy in which frequently required goods are placed close to the storage and retrieval area and rarely needed goods are placed far away from the storage and retrieval area.

Use the ABC strategy on the automated high-bay warehouse.

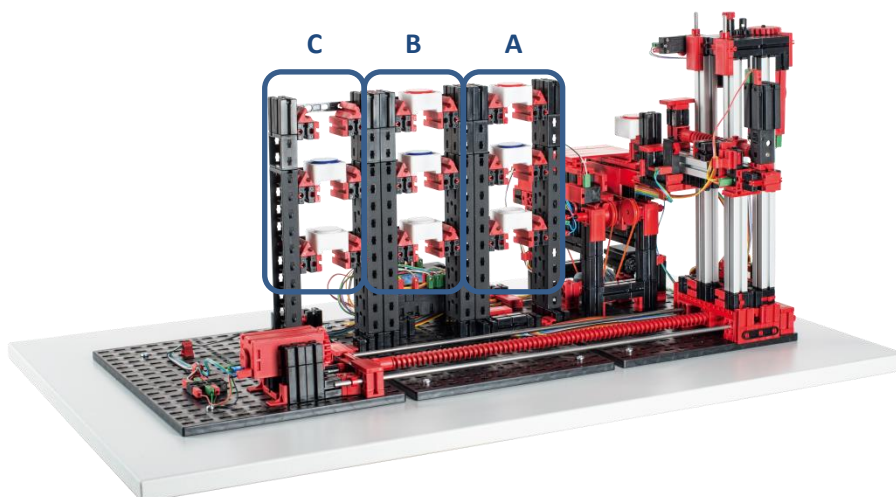

Maintenance and troubleshooting

The automated high-bay warehouse is generally maintenance free. If necessary the grease on the worms and worm screw nuts can be replaced. Keep in mind that it is possible to avoid a friction-type connection by applying a thin layer of grease at specific locations.

Problem: One of the three motors/axes is no longer moving.

Solution: Visually inspect the robot. Specifically check the cabling of the failed motor. If necessary, use a multimeter to check if there is a broken cable.

Problem: One of the three motors/axes moves beyond the specified position and no longer stops on its own.

Solution: Verify that the three encoder cable wires are correctly connected to the TXT controller. The "Interface Test" window may be helpful.

Problem: One of the three motors/axes no longer moves to the positions correctly and pauses briefly in front of the desired position.

Solution: Verify that the robot chucks and chuck nuts are secured tightly. If not, it is possible that there could be slippage between the friction lock parts.

Problem: The conveyor belt does not move or does not move far enough even though there is a workpiece on it.

Solution: One of the two conveyor belt light barriers is not working. Check the light barrier cables and make sure that they are not covered by shifting components. The "Interface Test" window may be helpful.

Problem: The high-bay rack feeder is brushing against the high bay storage rack or is not picking up the container correctly.

Solution: Adjust the positions of the program in the "Configuration" subroutine.

Problem: The high-bay rack feeder does not move from the high bay storage rack.

Solution: The position set on the high bay storage rack is incorrect. When picking up the workpiece carrier, the rack feeder must move upward. If the particular axis moves against a limit stop, the routine remains in an endless loop. To avoid this, adjust the position of this axis so that the workpiece carrier pickup routine does not extend past the limits.